

SG028 | 4.5L | 35 kVA

INDUSTRIAL SPARK-IGNITED GENERATOR SET

Generac International Products

Standby Power Rating - SG028

35 kVA, 28 kW, 50 Hz

Prime Power Rating - PG025

32 kVA, 25 kW, 50 Hz

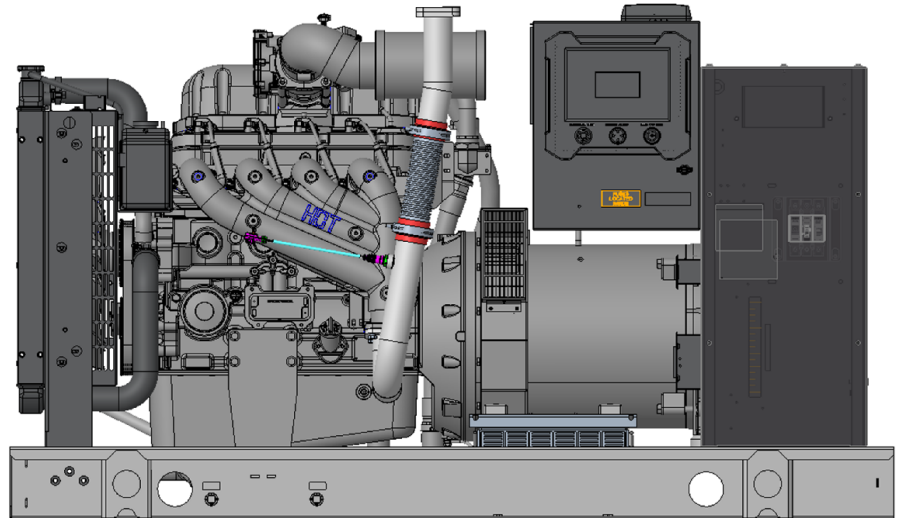

Image used for illustration purposes only



*Assembled in the USA using domestic and foreign parts

Codes and Standards

Not all codes and standards apply to all configurations. Contact factory for details.



BS5514 and DIN 6271



SAE J1349



NFPA 37, 70, 99, 110



NEC700, 701, 702, 708



ISO 3046, 7637, 8528, 9001



NEMA ICS10, MG1, 250, ICS6, AB1



ANSI C62.41

Powering Ahead

Generac ensures superior quality by designing and manufacturing most of its generator components, such as alternators, enclosures, control systems and communications software. Generac also makes its own spark-ignited engines, and you'll find them on every Generac gaseous-fueled generator. We engineer and manufacture them from the block up — all at our facilities throughout Wisconsin. Applying natural gas and LP-fueled engines to generators requires advanced engineering expertise to ensure reliability, durability and necessary performance. By designing specifically for these dry, hotter-burning fuels, the engines last longer and require less maintenance. Building our own engines also means we control every step of the supply chain and delivery process, so you benefit from single-source responsibility.

Plus, Generac Industrial Power's distribution network provides all parts and service so you don't have to deal with third-party suppliers. It all leads to a positive owner experience and higher confidence level. Generac spark-ignited engines give you more options in commercial and industrial generator applications as well as extended run time from utility-supplied natural gas.

STANDARD FEATURES

ENGINE SYSTEM

- Oil Drain Extension
- Air Cleaner
- Level 1 Fan and Belt Guards (Open Set Only)
- Stainless Steel Flexible Exhaust Connection
- Factory Filled Oil and Coolant
- Critical Silencer
- Oil Temperature Sender with Alarm
- Air Filter Restriction Indicator

Fuel System

- Fuel Line - NPT Connection
- Primary and Secondary Fuel Shutoff

Cooling System

- Closed Coolant Recovery System
- UV/Ozone Resistant Hoses
- Factory-Installed Radiator
- 50/50 Ethylene Glycol Antifreeze
- Radiator Drain Extension

Electrical System

- Battery Charging Alternator
- Battery Cables
- Battery Tray
- Rubber-Booted Engine Electrical Connections
- Solenoid Activated Starter Motor

ALTERNATOR SYSTEM

- GENprotect™
- Class H Insulation Material
- 2/3 Pitch
- Skewed Stator
- Brushless Excitation
- Sealed Bearing
- Full Load Capacity Alternator

GENERATOR SET

- Internal Genset Vibration Isolation
- Separation of Circuits - High/Low Voltage
- Separation of Circuits - Multiple Breakers
- Wrapped Exhaust Piping
- Standard Factory Testing
- 2 Year Limited Warranty (Standby Rated Units)
- 1 Year Limited Warranty (Prime Rated Units)

ENCLOSURE (If Selected)

- Rust-Proof Fasteners with Nylon Washers to Protect Finish
- High Performance Sound-Absorbing Material (Sound Attenuated Enclosures)
- Gasketed Doors
- Upward Facing Discharge Hoods (Radiator and Exhaust)
- Stainless Steel Lift Off Door Hinges
- Stainless Steel Lockable Handles
- RhinoCoat™ - Textured Polyester Powder Coat Paint

CONTROL SYSTEM



Power Zone® Pro Controller

- NFPA 110 Level 1 Compliant
- Engine Protective Functions
- Alternator Protective Functions
- Digital Engine Governor Control
- Digital Voltage Regulator
- Multiple Programmable Inputs and Outputs
- Remote Display Capability

- Remote Communication via Modbus® RTU, Modbus TCP/IP, and Ethernet 10/100
- Alarm and Event Logging with Real Time Stamping
- Expandable Analog and Digital Inputs and Outputs
- Remote Wireless Software Update Capable
- Wi-Fi®, Bluetooth®, BMS, and Remote Telemetry
- Built-In Programmable Logic Eliminates the Need for External Controllers Under Most Conditions
- Programmable I/O Channel Properties
- Built-In Diagnostics

Alarms and Warnings

- High/Low Oil Pressure
- High/Low Coolant Level
- High/Low Coolant Temperature
- Sender/Sensor Failure
- High/Low Oil Temperature
- Over Total kW
- Over/Under Speed
- Over/Under Voltage
- Over/Under Frequency
- Over Current
- High/Low Battery Voltage

- Battery Charger Current
- Phase to Phase and Phase to Neutral Short Circuits (I²T Algorithm)

4.3 Inch Color Touch Screen Display

- Resistive Color Touch Screen
- Easily Identifiable Icons
- Multi-Lingual
- On Screen Editable Parameters
- Key Function Monitoring
- Three Phase Voltage, Amperage, kW, kVA, and kVAr
- Selectable Line to Line or Line to Neutral Measurements
- Frequency
- Engine Speed
- Engine Coolant Temperature
- Engine Oil Pressure
- Engine Oil Temperature
- Battery Voltage
- Hourmeter
- Warning and Alarm Indication
- Diagnostics
- Maintenance Events/Information

SG028 | 4.5L | 35 kVA

INDUSTRIAL SPARK-IGNITED GENERATOR SET

Generac International Products

CONFIGURABLE OPTIONS

ENGINE SYSTEM

- Engine Coolant Heater
- Level 1 Fan and Belt Guards (Enclosed Units Only)
- Baseframe Cover/Rodent Guard
- Radiator Duct Adapter (Open Set Only)

FUEL SYSTEM

- Stainless Steel Flexible Fuel Lines

ELECTRICAL SYSTEM

- 10A Battery Charger
- Battery Warmer

ALTERNATOR SYSTEM

- Alternator Upsizing
- Anti-Condensation Heater
- Tropical Coating

CIRCUIT BREAKER OPTIONS

- Main Line Circuit Breaker
- 2nd Main Line Circuit Breaker
- 3rd Main Line Circuit Breaker
- Shunt Trip and Auxiliary Contact
- Electronic Trip Breakers

GENERATOR SET

- Extended Factory Testing (3-Phase Only)
- 8 Position Load Center
- Spring Vibration Isolators
- Pad Vibration Isolators

ENCLOSURE

- Weather Protected Enclosure
- Level 1 Sound Attenuated
- Level 2 Sound Attenuated
- Level 2 Sound Attenuated with Motorized Dampers
- Steel Enclosure
- Aluminum Enclosure
- Up to 321 KPH Wind Load Rating (Contact Factory for Availability)
- AC/DC Enclosure Lighting Kit
- Enclosure Heaters (with Motorized Dampers Only)

CONTROL SYSTEM

- 21-Light Remote Annunciator
- Remote Relay Assembly (8 or 16)
- Remote E-Stop (Break Glass-Type, Surface Mount)
- Remote E-Stop (Red Mushroom-Type, Surface Mount)
- Remote E-Stop (Red Mushroom-Type, Flush Mount)
- 10A Engine Run Relay
- Ground Fault Indication and Protection Functions
- 120V GFCI and 240V Outlets
- 100 dB Alarm Horn

WARRANTY (Standby Gensets Only)

- 2 Year Extended Limited Warranty
- 5 Year Limited Warranty
- 5 Year Extended Limited Warranty
- 7 Year Extended Limited Warranty
- 10 Year Extended Limited Warranty

ENGINEERED OPTIONS

CONTROL SYSTEM

- Spare Inputs (x4) / Outputs (x4)
- Battery Disconnect Switch

GENERATOR SET

- Special Testing
- Battery Box

SG028 | 4.5L | 35 kVA

INDUSTRIAL SPARK-IGNITED GENERATOR SET

Generac International Products

APPLICATION AND ENGINEERING DATA

ENGINE SPECIFICATIONS

General

Make	Generac
Cylinder #	4
Type	In-Line
Displacement - L (in ³)	4.5 (275.0)
Bore - mm (in)	114.3 (4.5)
Stroke - mm (in)	107.95 (4.25)
Compression Ratio	9.94:1
Intake Air Method	Naturally Aspirated
Number of Main Bearings	5
Connecting Rods	Forged Steel, Fractured Split, Bushingless
Cylinder Head	Cast Iron
Cylinder Liners	Cast Iron
Ignition	Coil Near Plug Solid State Inductive
Piston Type	Cast Aluminum Flat Top
Crankshaft Type	Forged Steel
Lifter Type	Hydraulic
Intake Valve Material	Stainless Steel
Exhaust Valve Material	Stainless Steel
Hardened Valve Seats	High Steel Iron Alloy

Engine Governing

Governor	Electronic
Frequency Regulation (Steady State)	±0.25%

Lubrication System

Oil Pump Type	Gear Driving
Oil Filter Type	Full-Flow Spin-On Cartridge
Crankcase Capacity - L (qt)	20 (21)

Cooling System

Cooling System Type	Pressurized Closed
Fan Type	Pusher
Fan Speed - RPM	2,100
Fan Diameter - mm (in)	508 (20)

Fuel System

Fuel Type	Natural Gas, Propane
Fuel Injection	Electronic
Fuel Shut Off	Generac
NG Operating Fuel Pressure - kPa (in H ₂ O)	1.2 - 3.5 (5 - 14)
LP Operating Fuel Pressure - kPa (in H ₂ O)	1.7 - 3.5 (7 - 14)

Engine Electrical System

System Voltage	12 VDC
Battery Charger Alternator	35 A
Battery Size	See Battery Index 0161970SBY
Battery Voltage	12 VDC
Ground Polarity	Negative

ALTERNATOR SPECIFICATIONS

Standard Model	R0028124Y21
Poles	4
Field Type	Revolving
Insulation Class - Rotor	H
Insulation Class - Stator	H
Total Harmonic Distortion	<5% (3-Phase Only)
Telephone Interference Factor (TIF)	<50

Standard Excitation	Synchronous Brushless
Bearings	Sealed Ball
Coupling	Direct via Flexible Disc
Prototype Short Circuit Test	Yes
Voltage Regulator Type	Full Digital
Number of Sensed Phases	All
Regulation Accuracy (Steady State)	±0.25%

SG028 | 4.5L | 35 kVA

INDUSTRIAL SPARK-IGNITED GENERATOR SET

Generac International Products

OPERATING DATA

POWER RATINGS

	Standby		Prime	
Single-Phase 110/220 VAC @1.0pf	28 kVA/28 kW	Amps: 127	25 kVA/25 kW	Amps: 115
Three-Phase 231/400 VAC @0.8pf	28 kVA/28 kW	Amps: 51	32 kVA/25 kW	Amps: 46

MOTOR STARTING CAPABILITIES (skVA)

skVA vs. Voltage Dip	
231/400 VAC	30%
R0028124Y21	82
R0048124Y21	104

FUEL CONSUMPTION RATES*

Percent Load	Natural Gas – m ³ /hr (scfh)		Propane – m ³ /hr (scfh)		
	Standby	Prime	Percent Load	Standby	Prime
25%	5.0 (177)	4.8 (170)	25%	2.6 (91)	2.5 (88)
50%	6.9 (245)	6.6 (232)	50%	3.3 (117)	3.2 (112)
75%	8.8 (310)	8.2 (290)	75%	4.0 (143)	3.8 (135)
100%	10.6 (376)	9.9 (350)	100%	4.8 (170)	4.5 (160)

* Fuel supply installation must accommodate fuel consumption rates at 100% load.

COOLING

		Standby	Prime
Air Flow (Fan Air Flow Across Radiator) - Open Set	m ³ /min (cfm)	82.5 (2,914.1)	
Coolant Flow	Lpm (gpm)	116.2 (30.7)	118.4 (31.3)
Coolant System Capacity	L (gal)	11.4 (3.0)	
Max. Operating Ambient Temperature	°C (°F)	50 (122)	
Maximum Operating Ambient Temperature (Before Derate)		See Bulletin No. 0199270SSD	
Maximum Additional Radiator Backpressure	kPa (in H ₂ O)	0.12 (0.5)	

COMBUSTION AIR REQUIREMENTS

	Standby	Prime
Flow at Rated Power - m ³ /min (cfm)	2.0 (69)	1.6 (55)

ENGINE

		Standby	Prime
Rated Engine Speed	RPM	1,500	1,500
Horsepower at Rated kW**	hp	43	39
Piston Speed	m/min (ft/min)	324 (1,063)	324 (1,063)
BMEP	kPa (psi)	484 (70)	433 (63)

EXHAUST

		Standby	Prime
Exhaust Flow (Rated Output)	m ³ /min (cfm)	6 (202)	5 (159)
Maximum Allowable Backpressure (Post Silencer)	kPa (inHg)	2.54 (0.75)	2.54 (0.75)
Exhaust Temp (Rated Output)	°C (°F)	601 (1,114)	596 (1,104)

** Refer to "Emissions Data Sheet" for maximum bHP for EPA and SCAQMD permitting purposes.

Deration – Operational characteristics consider maximum ambient conditions. Derate factors may apply under atypical site conditions.

Please contact a Generac Power Systems Industrial Dealer for additional details. All performance ratings in accordance with ISO3046, BS5514, ISO8528, and DIN6271 standards.

Standby - See Bulletin 0187500SSB

Prime - See Bulletin 0187510SSB

SG028 | 4.5L | 35 kVA
INDUSTRIAL SPARK-IGNITED GENERATOR SET

Generac International Products

DIMENSIONS AND WEIGHTS*

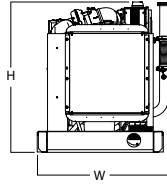
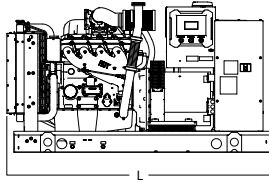

OPEN SET

L x W x H - mm (in)	1,981 (78.1) x 946 (37.3) x 1,128 (44.4)
Weight - kg (lbs)	760 - 793 (1,675 - 1,748)

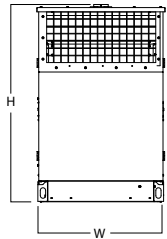
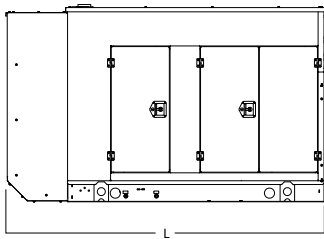

WEATHER PROTECTED ENCLOSURE

L x W x H - mm (in)	2,409 (94.8) x 965 (38.0) x 1,461 (57.5)
Weight - kg (lbs)	Steel: 980 - 1,013 (2,160 - 2,233) Aluminum: 859 - 891 (1,894 - 1,965)

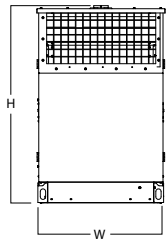
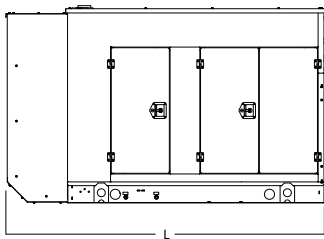

LEVEL 1 SOUND ATTENUATED ENCLOSURE

L x W x H - mm (in)	2,409 (94.8) x 965 (38.0) x 1,461 (57.5)
Weight - kg (lbs)	Steel: 1,024 - 1,056 (2,258 - 2,329) Aluminum: 901 - 935 (1,987 - 2,061)

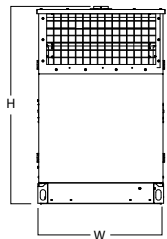
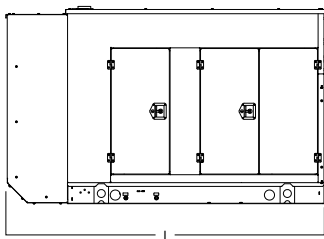

LEVEL 2 SOUND ATTENUATED ENCLOSURE

L x W x H - mm (in)	2,409 (94.8) x 965 (38.0) x 1,461 (57.5)
Weight - kg (lbs)	Steel: 1,062 - 1,095 (2,341 - 2,414) Aluminum: 939 - 972 (2,071 - 2,144)

* All measurements are approximate and for estimation purposes only.

YOUR FACTORY RECOGNIZED GENERAC INDUSTRIAL DEALER

Specification characteristics may change without notice. Please contact a Generac Power Systems Industrial Dealer for detailed installation drawings.